

INSTALLATION INSTRUCTIONS

Firewall-Mount Pedal Assemblies

A. Description

The Tilton Firewall-mount pedal assembly has been designed to provide the driver with the greatest control and comfort from a swing-style pedal assembly. The 6.2:1 pedal ratio delivers the optimum pedal profile. Firewall-mount pedal assemblies are NASCAR approved and the master cylinders must be mounted in the engine compartment.

Welded steel pedals provide the strength and durability to handle the most severe braking conditions. The pedal assembly is set up for dual brake master cylinders and includes the balance bar assembly. The balance bar allows adjustment of the brake pedal force distribution between the two master cylinders. This system can be used to compensate for fuel load changes, tire wear, and changing track conditions.

The Remote Brake Bias Adjuster is also available as an option. This connects to the balance bar and allows the driver to make balance bar adjustments quickly while on track.

Fluid reservoirs can be directly mounted to the master cylinders or can be remotely mounted based on your application. It is important to follow these setup instructions closely to realize the benefits of this design.



Master cylinders sold separately

Installation Notes

- Securing the pedal frame to a cross-member will greatly enhance the stability of the pedal assembly.
- The mounting location should suit the driver and also provide a stable platform.
- Be sure that there is no binding during the full stroke of the master cylinders when the pedal is depressed.
- The balance bar mechanism must clear all obstructions when the balance bar is adjusted to the extreme right or left-of-center.
- If you have decided to remotely mount the reservoirs, select the location for the reservoirs before starting installation.
- This is a gravity fed system, so the reservoirs must be located above the master cylinders.
- Attention must be paid to the routing and location of the hydraulic lines. Avoid heat sources such as exhaust pipes.
- Accurate clutch pedal setup is critically important. Improper clutch pedal installation and/or adjustment can result in expensive clutch damage and DNFs at the track!

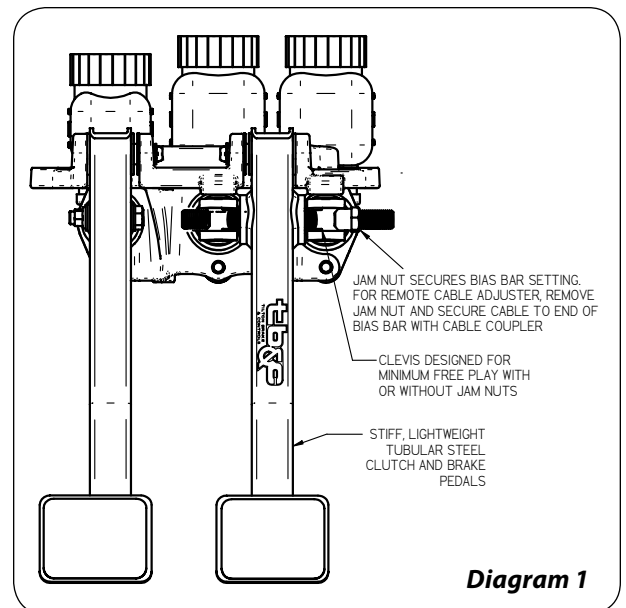
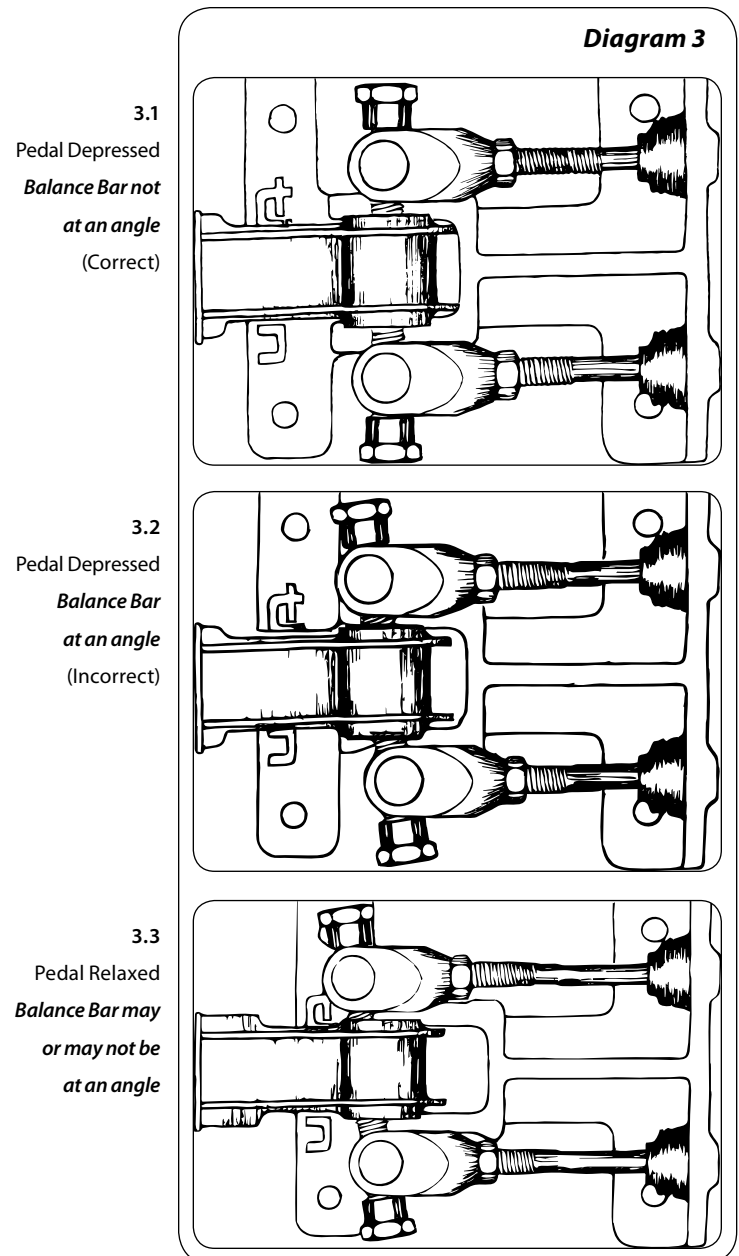
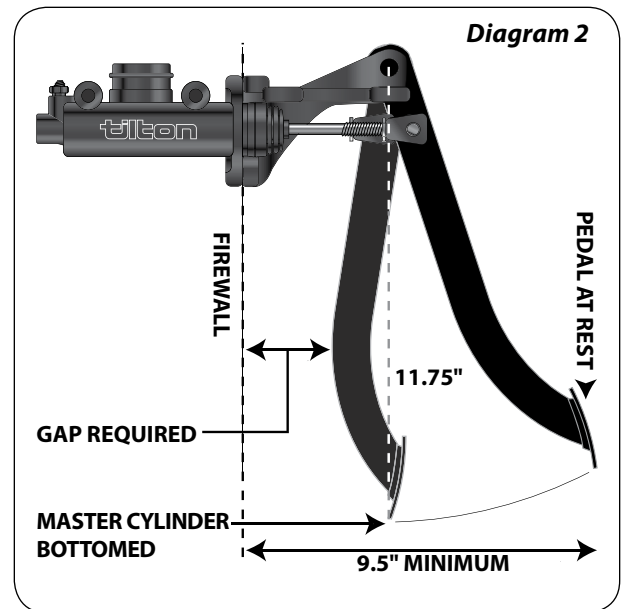

Diagram 1

B. Installation

1. Set the clevis center-to-center distance at 2.620 +/- .040". You need to do this before attaching the master cylinders.
2. Thread the adjusting shaft left or right until the spherical bearing is near the center of the pivot sleeve. Note that the right end of the balance bar has a longer threaded section and will stick out farther.
3. If you are using a remote adjuster, remove the jam-nut from the adjusting shaft. If you are not using a remote adjuster, tighten the jam-nut against the barrel nut on the longer end (right end) of the shaft. The round end goes against the barrel nut.
4. Mount the pedal assembly in the car. It is important to mount the frame rigidly so that it does not move when heavy pedal force is applied to both pedals. See diagrams 5–8 for mounting hole locations. The four large through holes are for attaching to the main support structure while the two tapped holes and the six master cylinder mounting studs (which often pass through a firewall) can be used for additional stiffening.
5. If you are going to bench bleed your master cylinders, now is the time.
6. Bolt the master cylinders into place with the supplied 5/16"-24 serrated flange nuts. Make sure the master cylinder pushrod has a jam-nut.
7. Thread the master cylinder pushrods into the clevises equal amounts (you may need to alter this later) until the pedal foot pad is in the correct position for the driver (See Diagram 2). A minimum of .25" thread engagement (6 threads) is recommended.
8. Tighten the master cylinder pushrod jam-nuts against the clevises.
9. Make sure that the chosen pedal position allows a full 1" of stroke at both master cylinders.
10. Make sure that the adjusted position also allows both master cylinders to return to their fully relaxed position without binding. Preload on the master cylinder pushrods can cause the brakes to lock up when hot when there is no force on the pedal.
11. Attach hydraulic lines.
12. Attach the reservoirs and bleed as directed in the master cylinder directions. With a balance bar, always bleed a front and a rear caliper at the same time to insure total air removal.
13. Apply the brakes and adjust the pushrod length so the adjusting shaft is parallel to the master cylinder mounting surface (See Diagram 3). If one pushrod is shortened by one revolution, lengthening the other by one revolution will maintain the same pedal position. Do not extend the pushrods to the point where they preload the master cylinder pistons. After adjusting, tighten the jam-nuts on both pushrods.
14. You will need to test drive the vehicle to determine if adjustments need to be made to the brake bias (front/rear brake force distribution). See Section F for making bias adjustments.



C. Clutch Pedal Setup

1. Install the clutch master cylinder using the supplied 5/16"-24 serrated flange nuts. Make sure that there is a jam-nut on the pushrod.
2. Thread the pushrod into the rod end on the clutch pedal until the pedal is in the desired position, which is usually a matter of driver preference. A minimum of .25" thread engagement (6 threads) is recommended. You may need to shorten the pushrod for some positions.
3. Tighten the master cylinder pushrod jam-nut against the spherical rod end.
4. Connect the hydraulic line to the master cylinder.
5. Fill the master cylinder reservoir with brake fluid. Do not use a silicone-based fluid.
6. Open the bleed fitting at the master cylinder, or loosen the line.
7. Gently depress and release the clutch pedal until fluid emerges.
8. Tighten the bleed fitting or line.
9. Fill the reservoir with brake fluid.
10. Place a light force on the pedal. You want enough to hold the bearing out against the clutch diaphragm spring but not enough to compress it.
11. Open the bleed screw for the hydraulic release bearing.
12. Completely stroke the pedal.
13. Close the bleed screw.
14. Let the pedal return to its natural position and wait 4 seconds.
15. Repeat steps 10-14 until all air is removed from the system.
16. Proceed directly to setting the pedal stop before stroking the pedal again or the clutch could be damaged. A pedal stop is usually required for small diameter racing clutches and/or hydraulic release bearings with limited stroke.

D. Clutch Pedal Stop Setup (For use with Tilton style hydraulic release bearings)

1. Raise the vehicle onto jack stands or a hydraulic lift.
2. With the engine off put the transmission into 1st gear and have someone attempt to rotate one of the drive wheels.
3. Depress the clutch pedal slowly until the clutch disengages and the drive wheel can be rotated.
4. Note the clutch pedal position at this point. This is labeled A in Diagram 4.
5. Adjust the pedal stop bolt to allow an additional 1/4" of pedal travel at the foot. This is labeled as point B in Diagram 4. Secure the pedal stop bolt with jam-nut once position has been set.
6. Adjust the pedal stop so the pedal cannot travel past point B.

E. Maintenance

Periodic inspections of the brake and clutch pedal assemblies should be conducted routinely. Pay particular attention to the balance bar and pivot areas.

Note: DO NOT reuse the snap rings found on the pedal pivot pins. These snap rings will yield when removed from the pivot pins if spread too far open. If replacements are needed, please order part number N5100-37 from your Tilton dealer.

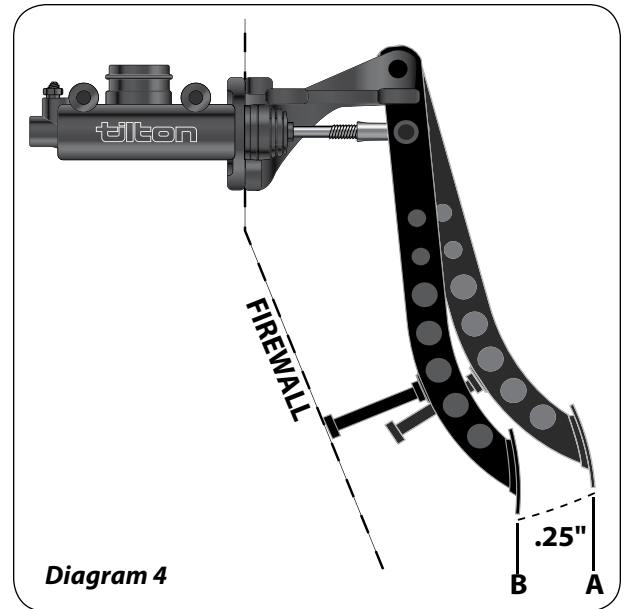

Diagram 4

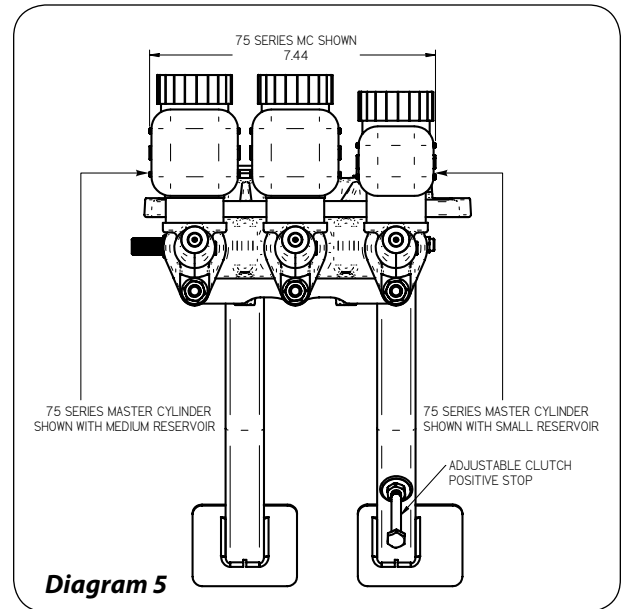

Diagram 5

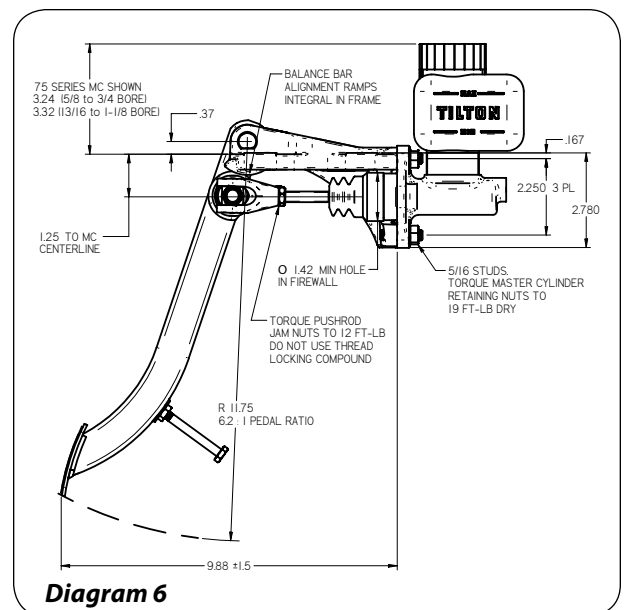

Diagram 6

F. Balance Bar Adjustment and Operation

When running on pavement, you want the front tires to lock-up with slightly less pedal pressure than the rear tires. This will help to keep the car stable and prevent it from going into a spin.

- Loosen the jam-nut on the adjusting shaft (Item 3 in Diagram 10).
A jam-nut is not used with a remote adjuster.
- Turn the adjusting shaft (Item 8 in Diagram 10) by hand or with the remote cable adjuster so that it advances the spherical bearing closer to the selected master cylinder, increasing the braking force produced by that master cylinder (Chart 2). The balance bar must be adjusted with the pedal in the relaxed position (Diagram D). It will not rotate while depressing the pedal.
- The balance bar has a fairly large adjustment range. However, if you find that what you need is outside of the adjustment range, you will need to make a master cylinder bore size change. There are three possible changes that can be made (See below). All three will allow the spherical joint to move back towards the center position.
 - Decrease the bore size of the master cylinder closest to the spherical joint by 1/8". This will decrease the amount of pedal force required from the foot and increase the amount of pedal travel.
 - Increase the bore size of the master cylinder farthest from the spherical joint by 1/8". This will increase the amount of pedal force required by the foot and decrease the amount of pedal travel.
 - Increase the bore size of the master cylinder farthest from the spherical joint by 1/16". Decrease the other master cylinder bore size by 1/16". This will maintain the amount of force and pedal travel while making a relatively large change to the front/rear brake bias.
- Whenever making an adjustment, remember to tighten the jam-nut (Item 3 in Diagram 10) afterwards. A jam-nut is not required when a Remote Brake Bias Adjuster is used.

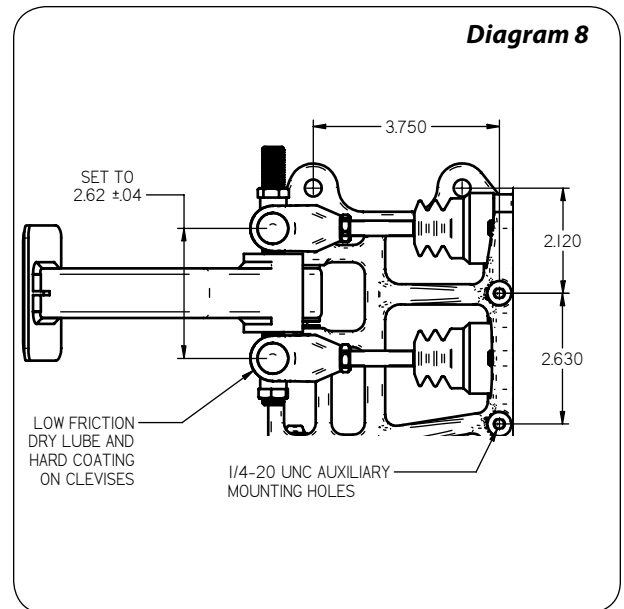
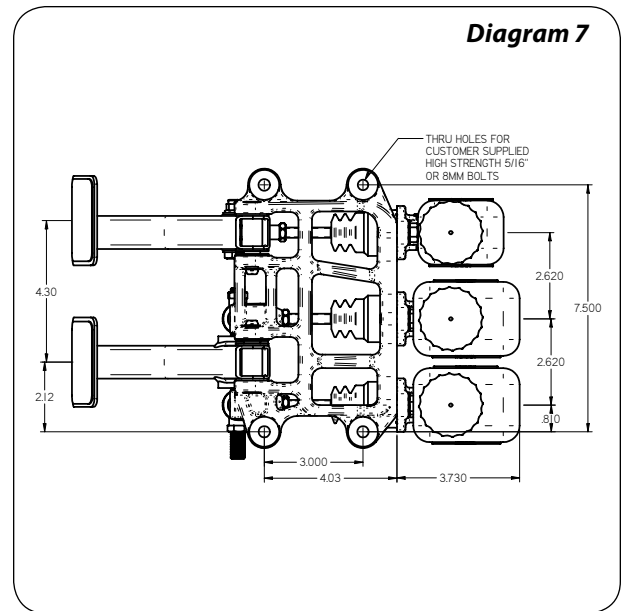

Diagram 9

Force Distribution (2.62" Clevis Center-to-Center)		
Spherical Joint Position	Left Clevis	Right Clevis
3/8" left-of-center	64.3%	35.7%
1/4" left-of-center	59.5%	40.5%
1/8" left-of-center	54.8%	45.2%
Centered	50.0%	50.0%
1/8" right-of-center	45.2%	54.8%
1/4" right-of-center	40.5%	59.5%
3/8" right-of-center	35.7%	64.3%

Diagram 10

