

TEMP-A-CURE™ OIL COOLERS

COOLING SYSTEMS

TEMP-A-CURE™ CURVED COOLERS



NEW!

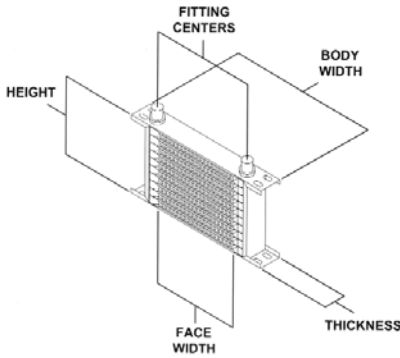

Earl's curved coolers are constructed with the same high grade aluminum and the same internal design as our standard 2" coolers, but have a curved design to fit neatly between the front forks of a motorcycle for maximum heat dissipation. The curved design allows for full wheel travel no matter where it is mounted on the forks. These coolers are only 1-1/4" thick and are available in two widths, three different heights and male -6 or -8 inlet and outlet fittings.

FACE WIDTH (BETWEEN TANKS)	8"	8"	11"	11"
FITTING CENTERS	9.05"	9.05"	11.618"	11.618"
BODY WIDTH	11.562"	11.562"	14.125"	14.125"
THICKNESS	1.25"	1.25"	1.25"	1.25"



ROW # & HEIGHT	FITTING SIZE	GRAY-NARROW	BLACK-NARROW	GRAY-WIDE	BLACK-WIDE
10 Row Height 3.050 nom	-6 AN Male	71006ERL	71006AERL	91006ERL	91006AERL
	-8 AN Male	71008ERL	71008AERL	91008ERL	91008AERL
13 Row Height 3.977 nom	-6 AN Male	71306ERL	71306AERL	91306ERL	91306AERL
	-8 AN Male	71308ERL	71308AERL	91308ERL	91308AERL
16 Row Height 4.919 nom	-6 AN Male	71606ERL	71606AERL	91606ERL	91606AERL
	-8 AN Male	71608ERL	71608AERL	91608ERL	91608AERL